

1. FLOW MAY BE IN EITHER DIRECTION
2. VALVE SHAFT WILL MEET OR EXCEED AWWA C504 REQUIREMENTS
3. REFERENCE AWWA C504 FOR FLANGES AND DRILLING (ANSI 125)
4. 29 TURNS TO CLOSE
5. (12) 7/8" BOLTS ON FLANGE (NO THREADED HOLES)
6. (8) 3/4" BOLTS ON MECH. JOINT
7. OPERATED BY 2" AWWA OPERATING / WRENCH NUT
8. RATED FOR 150PSI WORKING PRESSURE
9. GASKETS, GLANDS AND BOLTS FOR MECHANICAL JOINT FURNISHED WITH VALVE WHEN SPECIFIED ON ORDER

THIS DWG. AND ALL INFORMATION IS OUR PROPERTY AND SHALL NOT BE USED, COPIED, OR REPRODUCED WITHOUT WRITTEN CONSENT. DESIGN AND INVENTION RIGHTS RESERVED.



M&H VALVE COMPANY

A DIVISION OF McWANE INC.
P.O. BOX 2088
ANNISTON, ALABAMA 36202

DRAWN: CTJ
DATE: 10/20/2020
DWG. NO.
BD12-X11-M1110-11110

12" AWWA C504 BUTTERFLY VALVE
FLANGED END BY MECHANICAL JOINT - CL150
BURIED OPERATOR - OPEN LEFT
FA12 OPERATOR FLANGE

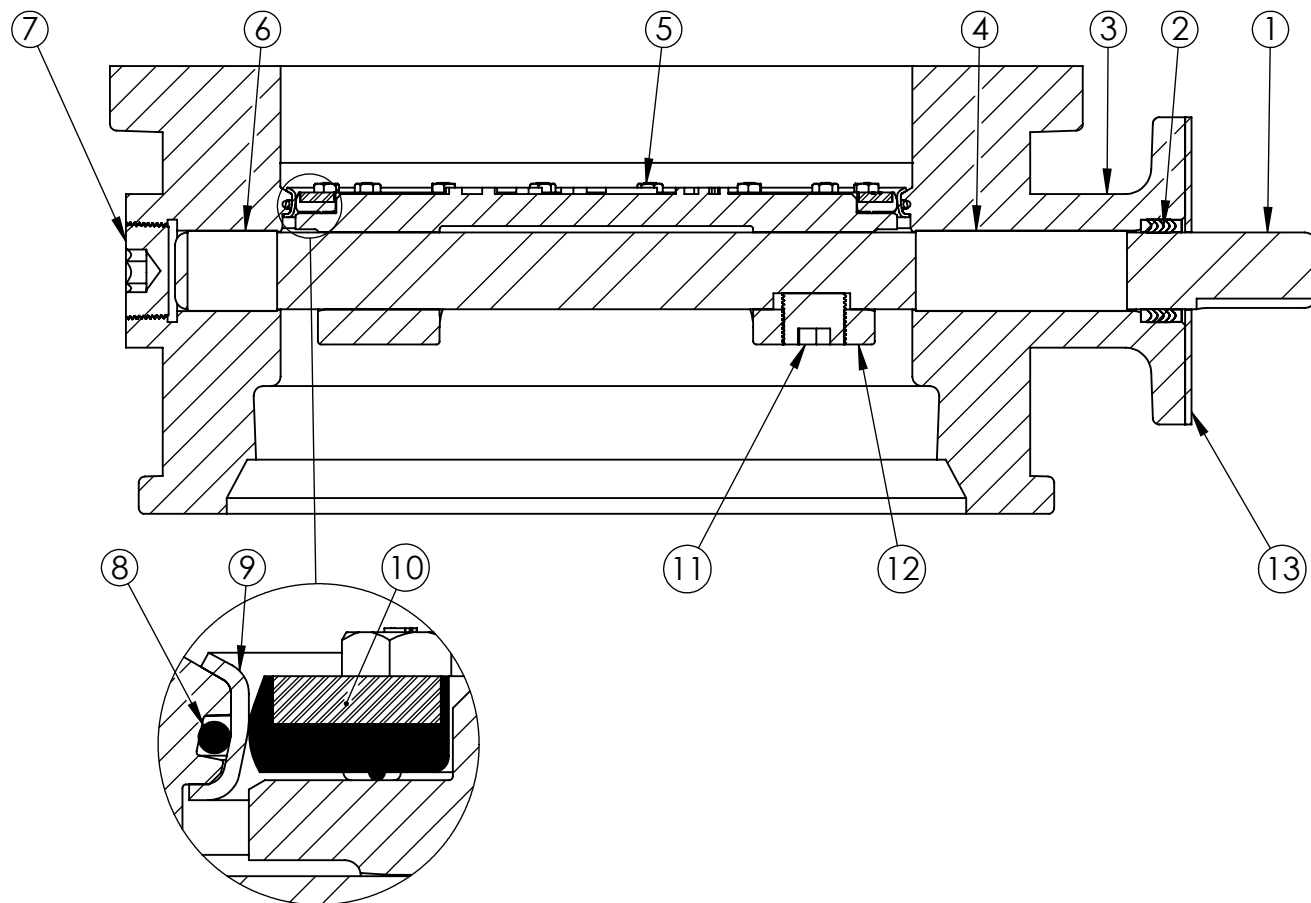

NOTES:

1. (*) SEAL PLATE PROVIDED WITH ALL BARESTEM VALVES, AND USED WITH ALL PURCHASED OPERATORS

| ITEM | DESCRIPTION | MATERIAL |
|------|------------------------------|---------------------------------|
| 1 | OPERATOR SHAFT | 304 STAINLESS STEEL, ASTM A-276 |
| 2 | V-RING PACKING | EPDM & BUNA-N |
| 3 | BUTTERFLY VALVE BODY | DUCTILE IRON, ASTM A-536 |
| 4 | UPPER JOURNAL BEARING | NYLATRON |
| 5 | VANE RING HEXHEAD CAP SCREWS | 18-8 STAINLESS STEEL |
| 6 | LOWER JOURNAL BEARING | NYLATRON |
| 7 | BODY END PLUG | STEEL |
| 8 | BODY O-RING | EPDM |
| 9 | BODY SEAT RING | 316 STAINLESS STEEL |
| 10 | VANE SEAT RING | EPDM W/ STAINLESS STEEL INSERT |
| 11 | VANE SHAFT TORGE PLUG | 18-8 STAINLESS STEEL |
| 12 | VANE | DUCTILE IRON, ASTM A-536 |
| 13 | SEAL PLATE * | STEEL |

THIS DWG. AND ALL INFORMATION IS OUR PROPERTY AND SHALL NOT BE USED, COPIED, OR REPRODUCED WITHOUT WRITTEN CONSENT. DESIGN AND INVENTION RIGHTS RESERVED.



M&H VALVE COMPANY

A DIVISION OF McWANE INC.
P.O. BOX 2088
ANNISTON, ALABAMA 36202

DRAWN: CTJ
DATE: 10/19/2020
DWG. NO.
BB12-X11-B0000-11110

12" AWWA C504 BUTTERFLY VALVE
FLANGED END BY MECHANICAL JOINT - CL150
BODY SUB-ASM MATERIAL LIST
FA12 OPERATOR FLANGE