

M&H 2 1/4 POST HYDRANT

ITEM#	QTY	DESCRIPTION	MATERIAL
1	1	HYDRANT SHOE/ELBOW	CAST IRON, ASTM A-126, CLASS B
2	1	STAND PIPE	DUCTILE IRON PIPE
3	1	NOZZLE SECTION	CAST IRON, ASTM A-126, CLASS B
4	1	BONNET	CAST IRON, ASTM A-126, CLASS B
5	1	MAIN VALVE ROD	STEEL C1117 HFS
6	1	OPERATING NUT	BRONZE ALLOY CDA 84400,ASTM B-584
7	1	LUBRICATION SCREW	BRASS
8	1	BONNET/OPERATING NUT O-RING	N.B.R.
9	1	HOLD DOWN NUT	BRONZE ALLOY CDA 84400,ASTM B-584
10	4	BONNET BOLTS	ELECTRO ZINC PLATED STEEL
11	4	BONNET NUTS	ELECTRO ZINC PLATED STEEL
12	1	BONNET GASKET	NON-ASBESTOS
13	*	HOZE NOZZLE	BRONZE ALLOY CDA 84400,ASTM B-584
14	*	HOZE NOZZLE SET SCREW	18-8 SS, ASTM F-593 GROUP 1
15	*	HOZE NOZZLE CAP	CAST IRON, ASTM A-126, CLASS B
16	*	HOZE NOZZLE CAP GASKET	RUBBER ASTM D2000
17	*	CHAIN	ELECTRO ZINC PLATED STEEL
18	1	STANDPIPE GASKET	NON-ASBESTOS
19	4	GROUND LINE STANDPIPE BOLTS & NUTS	18-8 STAINLESS STEEL
20	1	UPPER DRAIN VALVE	BRONZE
21	1	LOWER VALVE PLATE/BOTTOM PLATE	CAST IRON ASTM A-126, CLASS B
22	1	MAIN VALVE RUBBER SEAT	RUBBER
23	1	MAIN VALVE ACORN NUT	BRASS
24	1	BRONZE MAIN VALVE SEAT RING	BRONZE ALLOY CDA 84400,ASTM B-584
25	2	MAIN VALVE SEAT O-RINGS	N.B.R.
26	1	DRAIN VALVE FACINGS	EPDM
27	2	DRAIN VALVE RIVET	ALUMINUM
28	1	STEM PIN/VALVE ROD LOCK PIN	304 STAINLESS STEEL
29	1	HOZE NOZZLE O-RING	N.B.R.
30	1	OPERATING NUT HOLD DOWN O-RING	N.B.R.
31	1	LUBRICATING PLUG	STEEL
32	4	SHOE / ELBOW BOLTS & NUTS	18-8 STAINLESS STEEL
33	2	FLANGED LUG (HALF)	DUCTILE IRON
34	1	LOWER O-RING STEM SEAL	BUNA-N
35	1	1/4in DRAIN HOLE	-----

* VARIES BY STYLE NUMBER
 MAIN VALVE SIZE AVAILABLE: 2 1/4

MEETS OR EXCEEDS AWWA C502

150 PSI WORKING PRESSURE AWWA
 300 PSI HYDROSTATIC TEST PRESSURE

HYDRANT SHOE STYLES AVAILABLE:
 2" or 3" - MECHANICAL JOINT
 2"- THREADED JOINT

STYLE 33 - Post Hydrant with 1- 2 1/2" nozzle
 STYLE 133 - Post Hydrant with 1- 1 1/2" nozzle
 STYLE 233 - Post Hydrant with 2- 1 1/2" nozzles

DEPTH OF TRENCH -
 FROM THE GROUND
 LINE TO THE BOTTOM
 OF THE SHOE
 IN 6" INCREMENTS

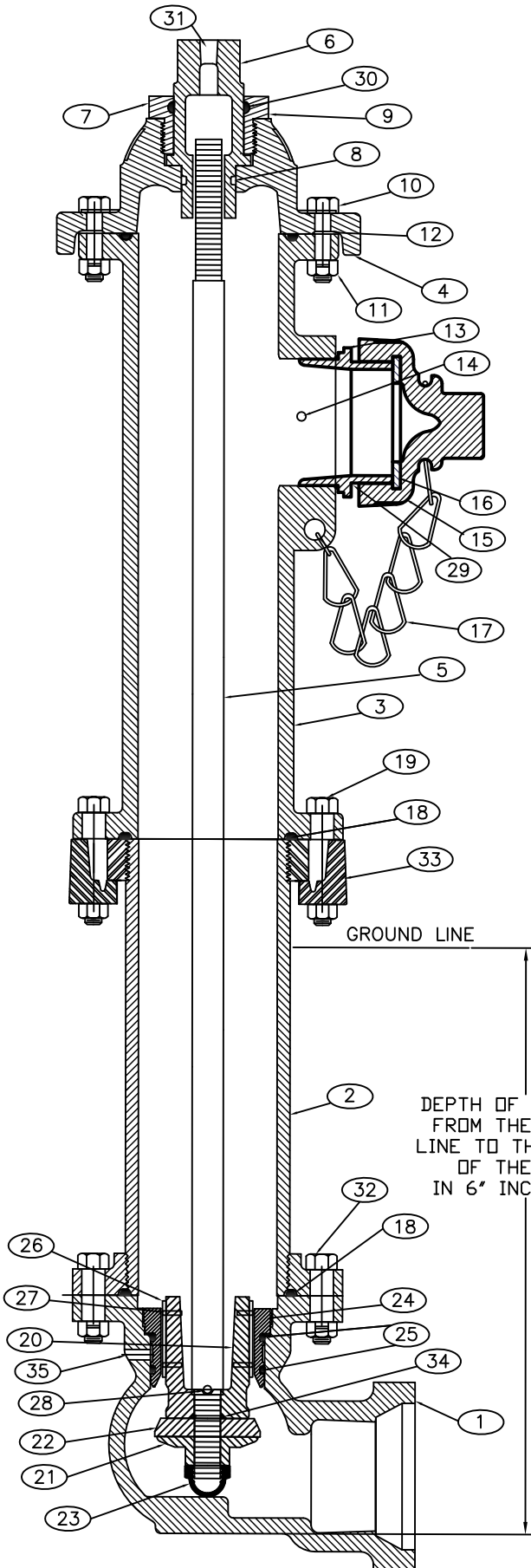

M&H VALVE COMPANY ANNISTON, ALABAMA A DIVISION OF MCWANE INC.	DWN: KLM
	DATE: 11/2014
	DWG. NO. FH-POST