

PARTS LIST					
ITEM	DESCRIPTION	REQ'D	MATERIAL	ASTM	
1	BODY	1	CAST IRON	A126	CL. B
2	SEAT RING	1	BRONZE	B62	
3	LIFT HANDLE DISC W/BR	1	STEEL	A107	GR. 1115
4	DISC RING	1	CAST IRON	A126	CL. B
5	RIGHT HAND WEDGE	1	CAST IRON	A126	CL. B
6	WEDGE BOLT	2	STEEL		ASA B18.2
7	HINGE BOLT	1	BRONZE	B62	
8	HINGE BOLT NUT	1	BRONZE	B62	
9	SET SCREW	1	STEEL		PLATED

FURNISHED WITH TWO FOOT LIFT HANDLE AND CATCH

LONGER LIFT HANDLE FURNISHED WHEN SPECIFIED

M&H VALVE COMPANY
ANNISTON, ALABAMA
A DIVISION OF MCWANE INC.

DWN: TRIJ
DATE: 7/1/05
DWG. NO.
SGV-A1

4" THRU 30" SHEAR GATES
VALVE ASSEMBLY / MATERIAL LIST
STYLE 44-02
FLANGED END

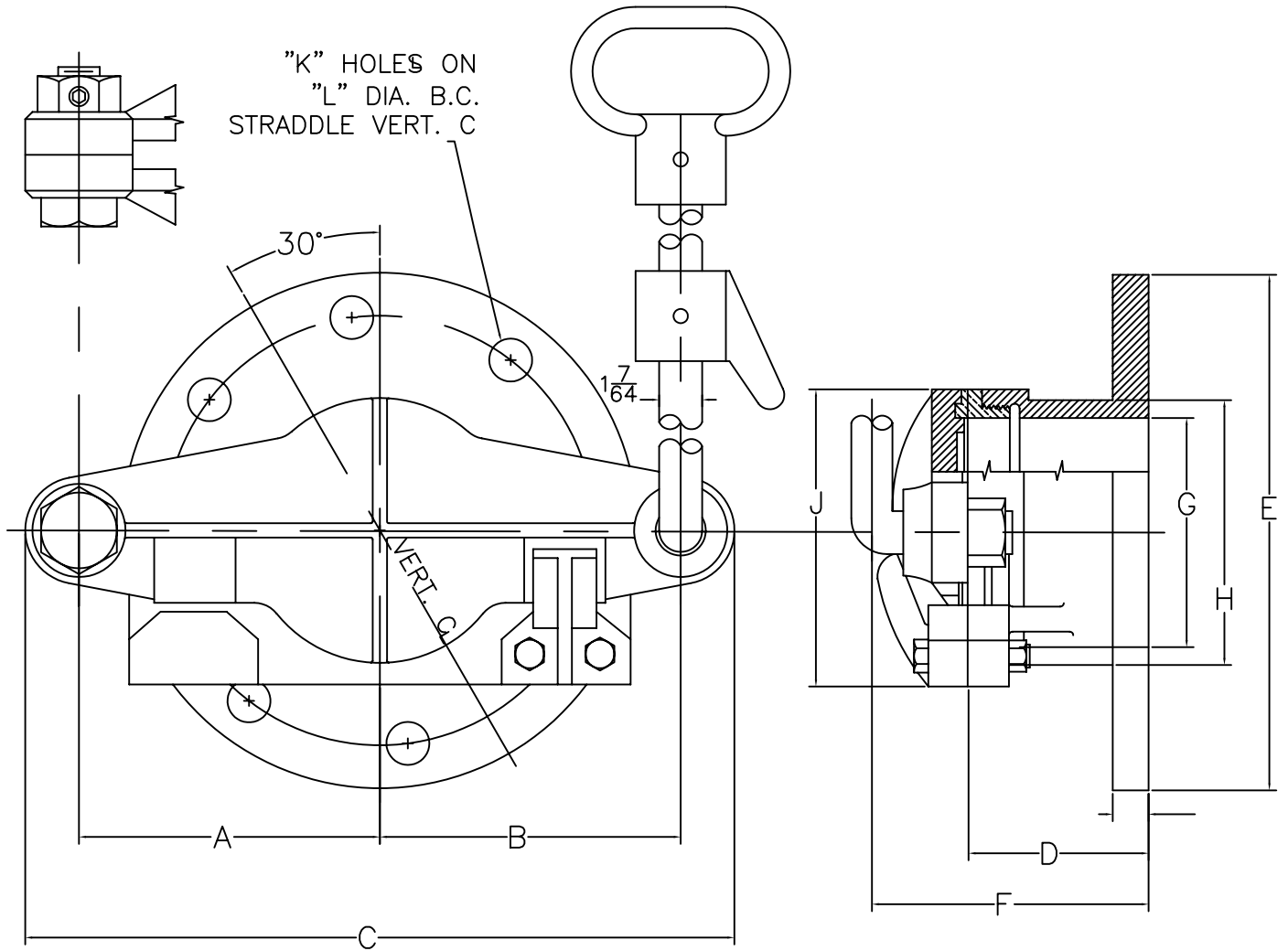

VALVE SIZE	4	6	8	10	12	14	16	18	20	24	30
A	5 1/4	6 1/2	8	9 3/8	11	13 1/2	14 1/2	15 1/2	18	21	24
B	5 1/4	6 1/2	8	9 3/8	11	13 1/2	14 1/2	15 1/2	18	21	24
C	12 3/8	15 1/8	18 3/8	21 3/8	24 3/4	31	33 1/2	36	41	47	53 1/2
D	3 1/4	3 3/8	3 5/8	4	4 3/8	4 3/4	5 1/2	6	6	6 1/2	6 1/2
E	9	11	13 1/2	16	19	21	23 1/2	25	27 1/2	32	38 3/4
F	5	5 1/4	5 3/8	6	6 5/8	7 1/4	8 9/16	9 3/8	9 1/2	10 1/2	10 3/4
G	4	6	8	10	12	14	16	18	20	24	30
H	4 5/8	6 3/4	8 3/4	10 7/8	13	15 1/4	17 1/4	19 1/4	21 1/2	25 3/4	32
I	5/8	11/16	3/4	13/16	7/8	1	1 1/8	1 1/4	1 1/4	1 3/8	1 1/2
J	5	7	9 1/4	11 1/2	13 1/2	15 3/4	18	20	22 1/4	26 1/4	32 3/4
K	8-3/4	8-7/8	8-7/8	12-1	12-1	12-1 1/8	16-1 1/8	16-1 1/4	20-1 1/4	20-1 3/8	28-1 3/8
L	7 1/2	9 1/2	11 3/4	14 1/4	17	18 3/4	21 1/4	22 3/4	25	29 1/2	36
WEIGHT	37	61	90	138	174	246	320	362	500	672	980

M&H VALVE COMPANY
ANNISTON, ALABAMA
A DIVISION OF MCWANE INC.

DWN: TRIJ
DATE: 7/1/05
DWG. NO.
SGV-A2

4" THRU 30" SHEAR GATES
GENERAL DIMENSIONS
STYLE 44-02
FLANGED END