

I - NUMBER & SIZE OF BOLTS

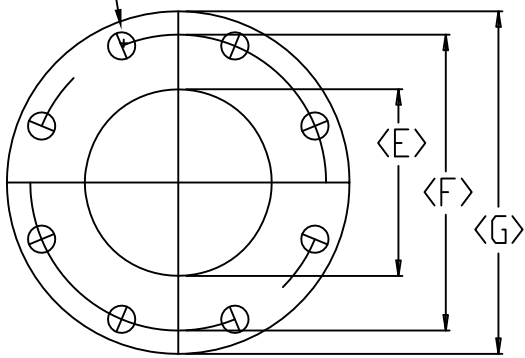

N - NUMBER & SIZE OF BOLTS

SIZE	A	B	C	D	E	F	G	H APPROX.	I	J	K	L	M	N	P	Q	R	WEIGHT
4x6	13.50	8.31	9	10.1	4	7.50	9	0.94	8-0.63	6	9.50	11	1	8-0.75	8.25	0.63	8.19	132
4x8	15	8.31	9	10.1	4	7.50	9	0.94	8-0.63	8	11.75	13.50	1.13	8-0.75	8.25	0.63	8.19	151
6x8	17	10.06	11	10.9	6	9.50	11	1	8-0.75	8	11.75	13.50	1.13	8-0.75	10.25	0.75	9.00	215
6x10	17.50	10.06	11	10.9	6	9.50	11	1	8-0.75	10	14.25	16	1.19	12-0.88	10.25	0.75	9.00	226
8x10	20	12.38	13.50	12.4	8	11.75	13.50	1.13	8-0.75	10	14.25	16	1.19	12-0.88	14.5	0.88	10.19	385
8x12	21	12.38	13.50	12.4	8	11.75	13.50	1.13	8-0.75	12	17	19	1.25	12-0.88	14.5	0.88	10.19	407
10x12	22.50	13.93	16.75	14.7	10	14.25	16	1.19	12-0.88	12	17	19	1.25	12-0.88	18	1.00	11.63	600

STYLE 3159-02A 2"-12" WITH RUBBER FACED CLAPPER
 STYLE 3159-02 2"-12" WITH BRONZE FACED CLAPPER

M&H VALVE COMPANY
 ANNISTON, ALABAMA
 A DIVISION OF MCWANE INC.

DWN: TRIJ
 DATE: 9/1/12
 DWG. NO.
 ICV-A1-LW

4" x 6" to 10" x 12"
 STYLE 3159-02
 INCREASING CHECK VALVE
 LEVER & WEIGHT
 (PAGE 1 of 2) DIMENSIONS

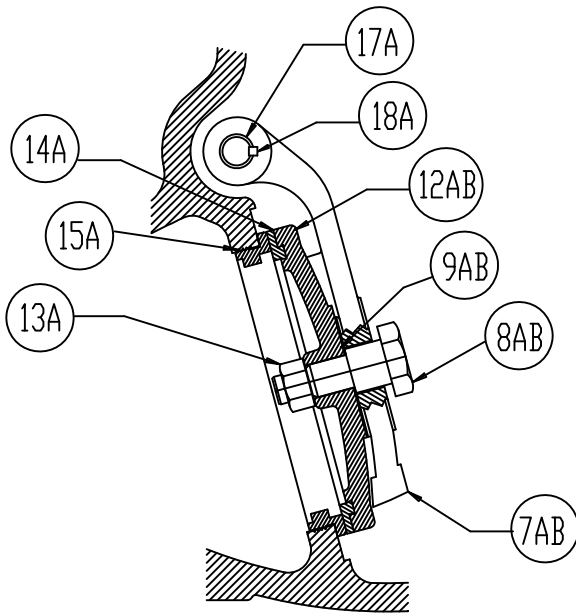

4" X 6" to 10" x 12"
LEVER & WEIGHT BRONZE SEATED DISC ASSEMBLY

7AB	1	HINGE W/KEYWAY	DUCTILE IRON A-536
8AB	1	DISC BOLT	(4'-8') STEEL---(10'-12') BRONZE
9AB	2	DISC BOLT WASHER (4'-8')	
12AB	1	DISC	CAST IRON A-126 CLASS B
13A	1	DISC NUT	18-8 STAINLESS STEEL
14A	1	DISC RING	BRONZE
15A	1	SEAT RING	BRONZE
17A	1	EXTENDED HINGE PIN	STAINLESS STEEL A-276 (304)
18A	2	KEY	STAINLESS STEEL A-276 (304)

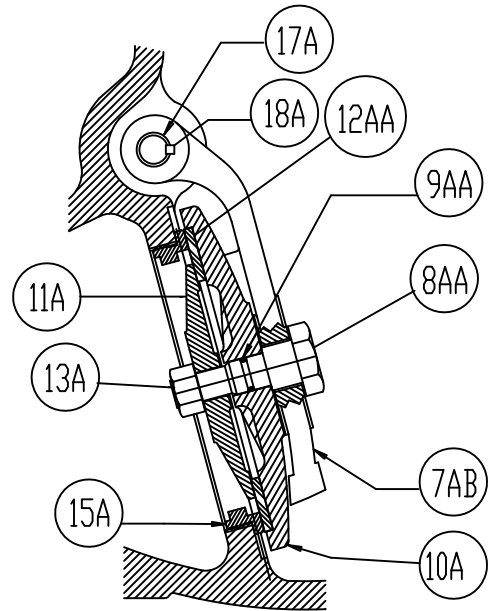

4" X 6" to 10" x 12"
LEVER & WEIGHT RESILIENT SEATED DISC ASSEMBLY

7AB	1	HINGE W/KEYWAY	DUCTILE IRON A-536
8AA	1	DISC BOLT	(4'-8') STEEL---(10'-12') BRONZE
9AA	1	DISC BOLT O-RING (10',12')	SYNTHETIC RUBBER
10A	1	DISC HOLDER	CAST IRON A-126 CLASS B
11A	1	DISC PLATE	BRONZE
12AA	1	DISC	SYNTHETIC RUBBER
13A	1	DISC NUT	18-8 STAINLESS STEEL
15A	1	SEAT RING	BRONZE
17A	1	EXTENDED HINGE PIN	STAINLESS STEEL A-276 (304)
18A	2	KEY	STAINLESS STEEL A-276 (304)

M&H VALVE COMPANY
ANNISTON, ALABAMA
A DIVISION OF MCWANE INC.

DWN: TRIJ
DATE: 9/1/12
DWG. NO.
ICV-A2-LW

4" x 6" to 10" x 12"
STYLE 3159-02
INCREASING CHECK VALVE
LEVER & WEIGHT
(PAGE 2 of 2)