

M&H Flush Type Hydrants are for use where traffic model hydrants protruding above ground might interfere with traffic in such places as airport runways and industrial areas. May be set in vaults or can be supplied with cast iron box and cover. This flush type hydrant sits completely underground and is accessible by simply lifting the box cover. Internal parts of the hydrant are exactly the same as the M&H 129 hydrant.

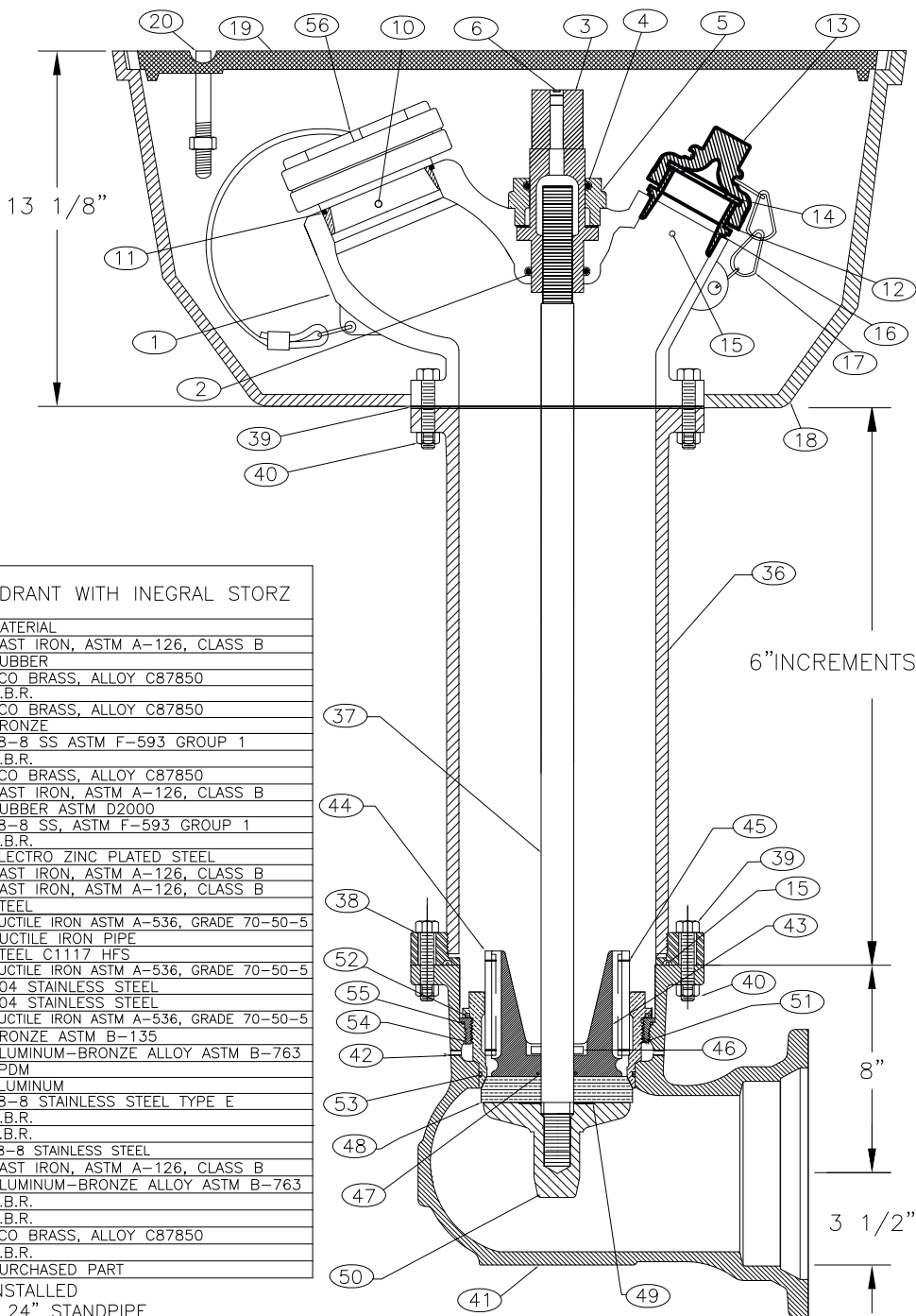

M&H MODEL 229 "FLUSH TYPE" FIRE HYDRANT WITH INTEGRAL STORZ

ITEM#	QTY	DESCRIPTION	MATERIAL
1	1	NOZZLE SECTION	CAST IRON, ASTM A-126, CLASS B
2	1	OP NUT O-RING SEAL	RUBBER
3	1	OPERATING NUT	ECO BRASS, ALLOY C87850
4	1	HOLD DOWN NUT "O" RING	N.B.R.
5	1	HOLD DOWN NUT	ECO BRASS, ALLOY C87850
6	1	LUBRICATING PLUG	BRONZE
10	1	PUMPER NOZZLE SET SCREW	18-8 SS ASTM F-593 GROUP 1
11	1	PUMPER NOZZLE "O" RING	N.B.R.
12	2	HOSE NOZZLE 2 1/2	ECO BRASS, ALLOY C87850
13	2	HOSE NOZZLE CAP	CAST IRON, ASTM A-126, CLASS B
14	2	HOSE NOZZLE CAP GASKET	RUBBER ASTM D2000
15	2	HOSE NOZZLE SET SCREW	18-8 SS, ASTM F-593 GROUP 1
16	2	HOSE NOZZLE "O" RING	N.B.R.
17	-	NOZZLE CAP CHAINS	ELECTRO ZINC PLATED STEEL
18	1	HYDRANT BOX	CAST IRON, ASTM A-126, CLASS B
19	1	HYDRANT BOX COVER	CAST IRON, ASTM A-126, CLASS B
20	1	HYDRANT BOX COVER HANDLE	STEEL
35	*1	STAND PIPE UPPER FLANGE	DUCTILE IRON ASTM A-536, GRADE 70-50-5
36	1	STAND PIPE	DUCTILE IRON PIPE
37	1	MAIN VALVE ROD	STEEL C1117 HFS
38	*1	STAND PIPE LOWER FLANGE	DUCTILE IRON ASTM A-536, GRADE 70-50-5
39	16	SHOE/NOZZLE BOLTS 5/8-11 X 3 1/2	304 STAINLESS STEEL
40	16	SHOE/NOZZLE NUTS 5/8-11	304 STAINLESS STEEL
41	1	HYDRANT SHOE/ELBOW	DUCTILE IRON ASTM A-536, GRADE 70-50-5
42	2	DRAIN HOLE BUSHINGS	BRONZE ASTM B-135
43	1	UPPER DRAIN VALVE/UPPER VALVE PLATE	ALUMINUM-BRONZE ALLOY ASTM B-763
44	2	DRAIN VALVE FACINGS	EPDM
45	8	DRAIN VALVE FACING RIVETS	ALUMINUM
46	1	LOWER STEM PIN 3/8" X 2-1/8"	18-8 STAINLESS STEEL TYPE E
47	1	LOWER STEM "O" RING SEAL	N.B.R.
48	1	MAIN VALVE RUBBER/SEAT	S.B.R.
49	1	LOWER VALVE PLATE LOCKWASHER	18-8 STAINLESS STEEL
50	1	LOWER VALVE PLATE/BOTTOM PLATE	CAST IRON, ASTM A-126, CLASS B
51	1	BRONZE MAIN VALVE SEAT RING	ALUMINUM-BRONZE ALLOY ASTM B-763
52	1	MAIN VALVE SEAT RING UPPER "O" RING	N.B.R.
53	1	MAIN VALVE SEAT RING LOWER "O" RING	N.B.R.
54	*1	SHOE RETAINER RING	ECO BRASS, ALLOY C87850
55	*1	SHOE RETAINER RING "O"-RING	N.B.R.
56	1	INTEGRAL STORZ WITH CABLE	PURCHASED PART

* NOT FIELD REPLACEABLE - PERMANENTLY INSTALLED
 BURY EXAMPLE: 4 FOOT BURY HYDRANT HAS 24" STANDPIPE

MAIN VALVE SIZES AVAILABLE: 5 1/4"

250 PSI WORKING PRESSURE
 500 PSI HYDROSTATIC TEST PRESSURE

HYDRANT SHOE STYLES AVAILABLE:
 6" - MECHANICAL JOINT
 6" - FLANGED

M&H VALVE COMPANY
 ANNISTON, ALABAMA
 A DIVISION OF MCWANE INC.

DWN: KLM

DATE: 10/2015

DWG. NO.
 FH-229-ISZ