

### SHAFT INFORMATION

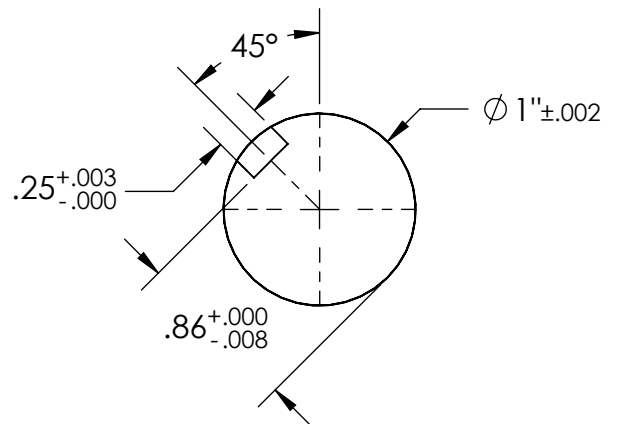

1. FLOW MAY BE IN EITHER DIRECTION
2. VALVE SHAFT WILL MEET OR EXCEED AWWA C504 REQUIREMENTS
3. REFERENCE C504 FOR FLANGES (250B) AND DRILLING (ANSI 250)
4. ASME B16.1 CL250 FLANGES W/ RAISED FACE & STANDARD DRILLING
5. (12) 3/4" BOLTS ON EACH FLANGE (4 THREADED HOLES, 3/4"-10 UNC, THREADED THRU)
6. RATED FOR 250psi WORKING PRESSURE

THIS DWG. AND ALL INFORMATION IS OUR PROPERTY AND SHALL NOT BE USED, COPIED, OR REPRODUCED WITHOUT WRITTEN CONSENT. DESIGN AND INVENTION RIGHTS RESERVED.



**M&H VALVE COMPANY**

A DIVISION OF McWANE INC.  
P.O. BOX 2088  
ANNISTON, ALABAMA 36202

DWG. NO.

BD06-F43-B0000-11210

DRAWN: EMW

REV.

DATE: 04/20/2021

-

6" AWWA C504 BUTTERFLY VALVE  
FLANGED END - RATED CL250  
BARESTEM  
FA12 MSS/ISO ADAPTER

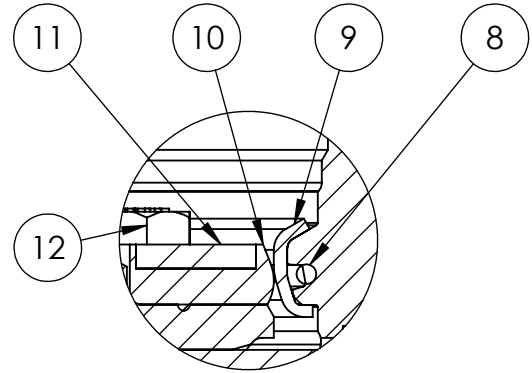
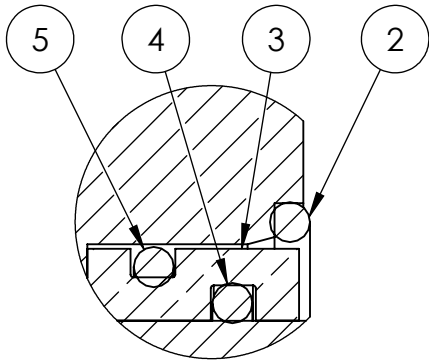
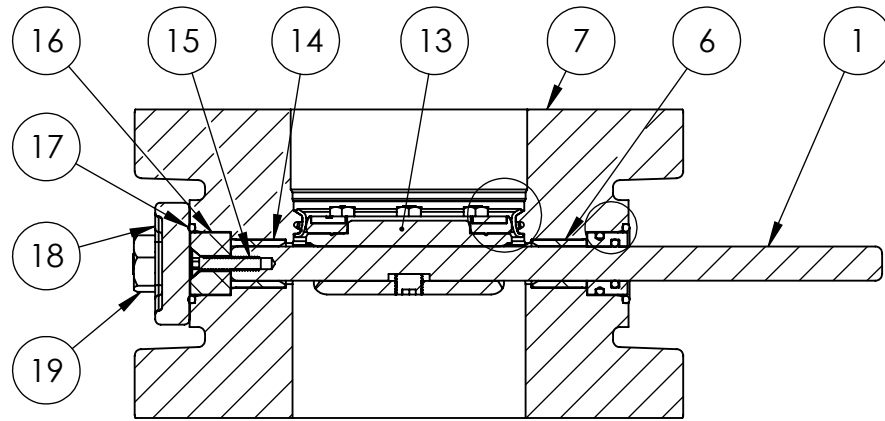

ITEM NO.	DESCRIPTION	MATERIAL
1	OPERATOR SHAFT	630 STAINLESS STEEL, ASTM A-564
2	OPERATOR O-RING	EPDM
3	CARTRIDGE SEAL	BRONZE
4	CARTRIDGE SEAL O-RING (INSIDE)	BUNA-N
5	CARTRIDGE SEAL O-RING (OUTSIDE)	BUNA-N
6	UPPER BODY BUSHING	DELRIN
7	VALVE BODY	DUCTILE IRON, ASTM A-536, GR 70-50-05
8	BODY O-RING	EPDM
9	BODY SEAT RING	316 STAINLESS STEEL, ASTM A-276
10	VANE SEAT RING	EPDM
11	VANE CLAMP RING	304 STAINLESS STEEL, ASTM A-276
12	VANE BOLTS	18-8 STAINLESS STEEL
13	VANE	DUCTILE IRON, ASTM A-536, GR 70-50-05
14	LOWER BODY BUSHING	DELRIN
15	BEARING CAP SCREW	18-8 STAINLESS STEEL
16	THRUST BEARING	BRONZE
17	END COVER O-RING	EPDM
18	END COVER	DUCTILE IRON, ASTM A-536, GR 70-50-05
19	END COVER BOLTS	18-8 STAINLESS STEEL

THIS DWG. AND ALL INFORMATION IS OUR PROPERTY AND SHALL NOT BE USED, COPIED, OR REPRODUCED WITHOUT WRITTEN CONSENT. DESIGN AND INVENTION RIGHTS RESERVED.



**M&H VALVE COMPANY**

A DIVISION OF McWANE INC.  
P.O. BOX 2088  
ANNISTON, ALABAMA 36202

DWG. NO.

BBAA-F43-B0000-11110

DRAWN: EMW

REV.

DATE: 04/14/2021

-

3" - 12" AWWA C504 BUTTERFLY VALVE  
FLANGED ENDS - RATED CL250  
BODY SUB-ASM MATERIAL LIST