

NO.	DESCRIPTION	MATERIAL	ASTM DESIGNATION	QTY
1	BODY	DUCTILE IRON	A536 GR. 65-45-12 / 70-50-05	1
2	COVER	DUCTILE IRON	A536 GR. 65-45-12 / 70-50-05	1
3	FLAPPER ASSEMBLY	DUCTILE IRON	A536 GR. 65-45-12 / 70-50-05	1
		EPDM COATED	D2000	
4	BOLT	STEEL	F593 S30400	6
5	NUT	STEEL	F594 S30400	6
6	O-RING	RUBBER	D2000	1

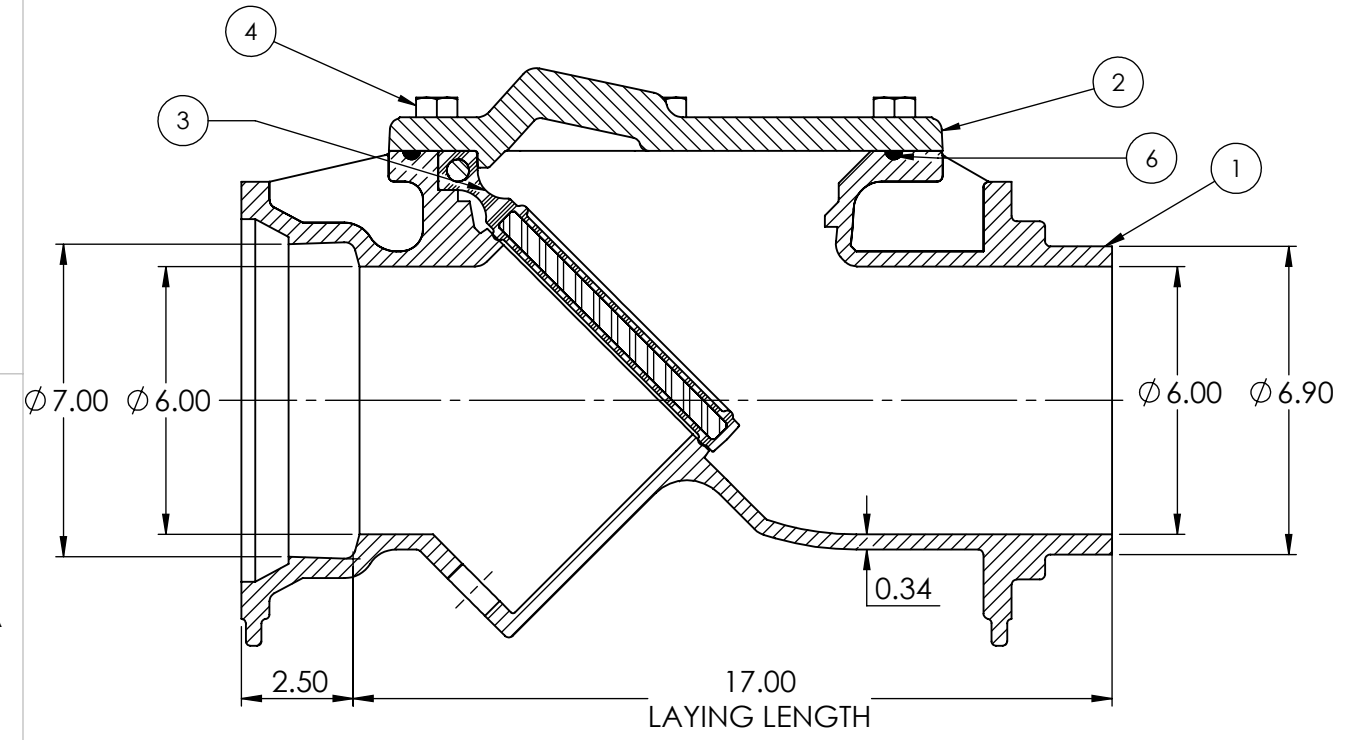
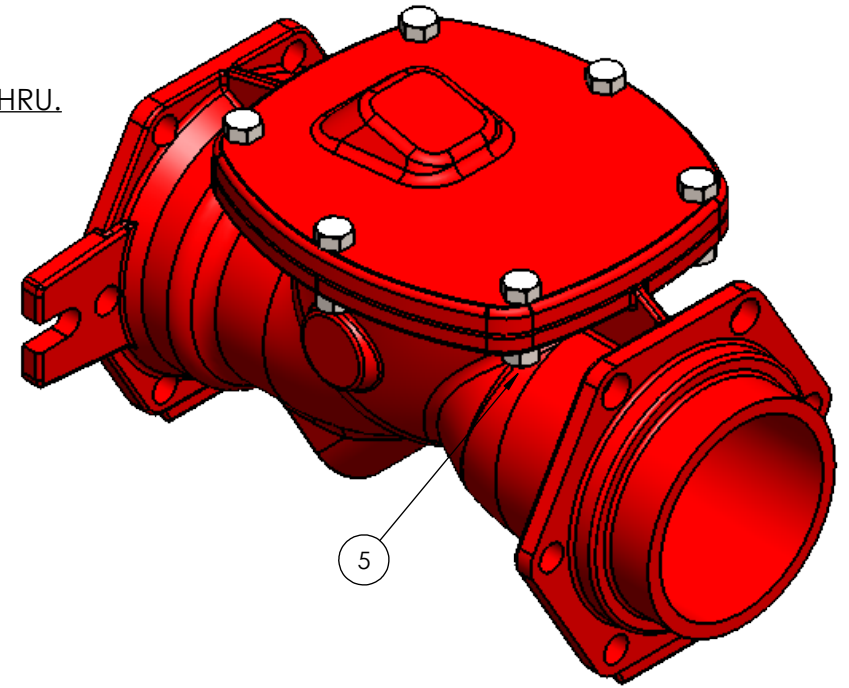
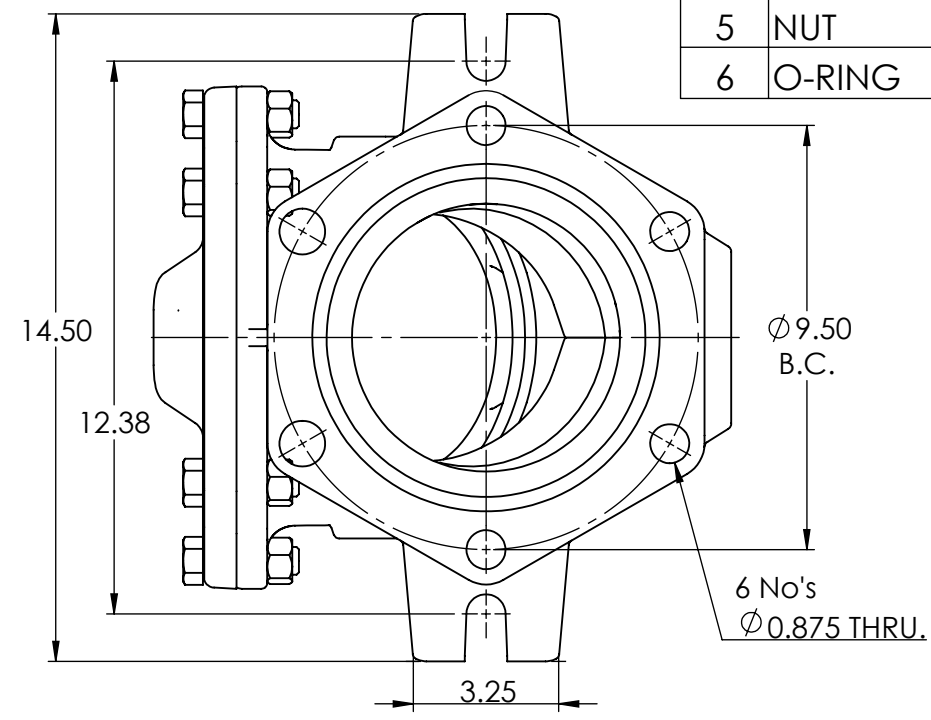
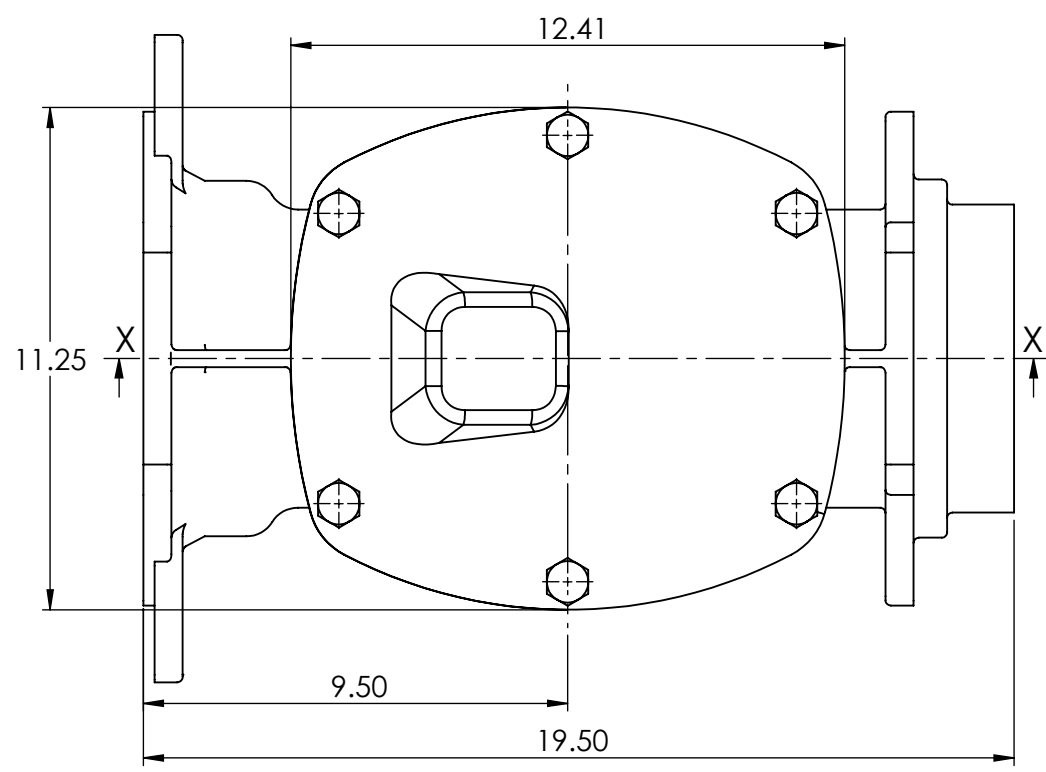

NO.	DATE	ECN	REVISION
-	-	-	-
1	7/12/18	ECN-3116	INITIAL RELEASE

PROPRIETARY AND CONFIDENTIAL
 THE INFORMATION CONTAINED IN THIS DRAWING IS THE SOLE PROPERTY OF Kennedy Valve Co.. ANY REPRODUCTION IN PART OR AS A WHOLE WITHOUT THE WRITTEN PERMISSION OF Kennedy Valve Co. IS PROHIBITED.
 DESIGN & INVENTION RIGHTS RESERVED

UNLESS OTHERWISE SPECIFIED:		NAME	DATE
CASTING DIM:		INDIA	4/24/18
0" - 4" +/- 1/32"		DSB	7/20/18
4" - 8" +/- 3/64"			
8" - 12" +/- 1/16"			
12" - 18" +/- 3/32"			
18" - UP +/- 1/8"			
RADII 1/8"			
DRAFT 2			
MACHINING DIM:			
DUAL DIM. INCHES[MM]			
FRACTIONAL ± 1/64			
ANGULAR ± .5			
RADII 1/32"			
TWO PLACE DECIMAL ± .02			
THREE PLACE DECIMAL ± .005			
DO NOT SCALE DRAWING			

M&H Valve Co.
 Division of McWane, Inc.
 Valve & Hydrant Group

MH

TITLE: **FIGURE 507, 6" MJ CHECK VALVE ASSEMBLY**

SIZE	PART NO.	DWG. NO.	REV
D		81791	1

SCALE: WEIGHT: SHEET 1 OF 1